



**AKSA Power Generation** has been producing industrial generator sets with an innovative compact design and excellence in quality for over 30 years. AKSA has been providing reliable power through three main production plants and over 15 branch offices worldwide.

**General Characteristics**

Model Name	APD-NG100
Engine Make	PSI
Engine Model	5.7LT-CAC
Alternator Make	Stamford
Control Panel Make & Model	DSE 7320
Frequency & Speed	60Hz, 1800rpm
Enclosure Make & Model	AKSA AUL 41/42



**Genset Rating**

Engine	Alternator	Voltage	PF	NG Standby Power	NG Standby Current	LP Gas Standby Power	LP Gas Standby Current
5.7LTCAC	UCI274D (Wnd-311)	480/277V	0.8	100kW	150A	80kW	120A
	UCI274D (Wnd-06)	240/120V,1ph	1	100kW	416A	80kW	333A
	UCI274D (Wnd-311)	208/120V	0.8	100kW	347A	80kW	277A
	UCI274D (Wnd-17)	600/347V	0.8	100kW	120A	80kW	96A

**\*EPA – Certified for Emergency Stationary Applications**

Stand-by Power (Maximum): Power available at variable load in the event of main power network failure. No over load is permitted.  
 Prime Power: Power available at variable load in lieu of a main power network. Overload of 10% is permitted for 1 hour in every 12 hours of operation.  
 The above ratings represent the engine performance capabilities to conditions specified in accordance with ISO 8528/5 & ISO3046.  
**Derating may be required for conditions outside of the test conditions.**

**Codes & Standards**

The Generator set is designed and manufactured in a facility certified to **ISO9001** standards.

The Generator set is designed and manufactured in a facility certified to **ISO14001:2015** standards.

**AKSA Power Generation** provides **single source responsibility** for the generator set & accessories.

The generator set, with its components, are **prototype tested** and **production tested** according to the UL test program.

The generator set meets **NFPA70, 99, 110, 37** Level 1 when equipped with the necessary accessories and installed per NFPA standards.



\*Manufacturer reserves the right to make changes in model, technical specifications, color, equipment and accessories without prior notice.



### Engine Data

Manufacturer	PSI
Model	5.7LT-CAC
Displacement & Cylinders	5.7L / 8 Cylinders
Engine Type	V-type, 4 Cycle
Engine Speed	1800rpm
Engine Standby Power NG	122 Kw
Engine Standby Power LP	111.16 kW
Aspiration	Forced Induction
Compression Ratio	9.4 : 1
Bore / Stroke	101.6 mm / 88.4 mm
Governor type	Electronic

### Fuel System

Fuel Type	NG, LP Gas/Dual Fuel
Min NG Supply pipe size	1-1/4" NPT
Min LPG Supply pipe size	3/4"
Maximum EPR Rated Pressure	6.9 kPa / 1.0 psi
Max Pressure to EPR	2.7 kPa / 11.0 inH2O
Min Pressure to EPR	1.7 kPa / 7.0 inH2O

### Fuel Consumption

	Natural Gas	LP Gas
Standby Power (100%)	1380 cfh 39.1 m <sup>3</sup> /hr	510 cfh 14.4 m <sup>3</sup> /hr
Standby Power (75%)	1125 cfh 31.8m <sup>3</sup> /hr	410 cfh 11.6 m <sup>3</sup> /hr
Standby Power (50%)	780 cfh 22.1 m <sup>3</sup> /hr	290 cfh 8.21 m <sup>3</sup> /hr
Standby Power (25%)	550 cfh 15.5 m <sup>3</sup> /hr	180 cfh 5.1 m <sup>3</sup> /hr

### Electric System

System Voltage (dc)	12V
Battery Qty, Rating	1 x 60Ah,

### Cooling System

Radiator Cooling System Type	Closed Circuit
Coolant Capacity, engine only	8.1 quart
Cranking Temperature	160 °F
Full Open Temperature	185 °F

### Exhaust System

Type	Air cooled manifold
Max. allowable back pressure	10.2 kPa
Cont. rating catalyst configuration	Dual Substrate
Exhaust Gas Flow at Rated Power @ 1350 °F	845.9 cfm

### Air Intake System

Combustion Air Required	262 cfm
Max Intake Air Restriction (Clean Element)	1.49 kPa /3 inH2O
Air Filter Type	Dry Paper Element

### Lubrication System

Oil Specifications	SAE 5W-30 API Rating SM or Newer
Oil Pan Capacity	5.0 Qts
Oil filter; qt, type	1, Cartridge
Max allowable oil temp	250 °F



### Alternator Data

Manufacturer	Stamford
Standards	BS EN 60034
Control System	PMG
A.V.R.	MX341
Voltage Regulation	± 1 %
Insulation System	Class H
Protection	IP23
Rated Power Factor	0.8
Stator Winding	Double Layer Concentric
Winding Pitch	Two Thirds
Winding Leads	12
Telephone Interference	THF < 2 %
Waveform Distortion	No Load < 1.5 %
Maximum Over speed	2250 rev/min

### Battery Charger & Electrical System Data

Manufacturer	ComAp
Model	InteliCharger
Input Voltage	85V ~ 264V AC
Output Voltage / Current	13.8V Float / 4A pk

### Jacket Water Heater Data

Manufacturer	Hotstart
Model	TPS101GT10-000
Input Voltage	120V
Power	1000W

### Controller Data

Manufacturer	DSE
Model	7320 MK II

### Controller Features & Benefits

- Microprocessor controlled, UL & NFPA110 Compatible
- License free PC Software (Non-proprietary Software)
- IP65 rating offers increased resistance to water ingress
- Modules can be integrated to building management systems
- Real time clock provides accurate event log
- Four line back-lit LCD text display
- Five key menu navigation, two wire start/stop at Auto mode
- Front panel editing with PIN protection
- Support up to three remote display modules
- Configurable timers and alarms
- Multiple date and timer scheduler
- Integral PLC editor
- 'Protections disabled' feature
- Load switching (load shedding and dummy load outputs)
- Fully configurable via DSE Configuration Suite PC Software
- SCADA monitoring via DSE Configuration Suite PC Software

### Protection

- ✓ Gen. Voltage – under / over
- ✓ Gen. Freq. – under / over
- ✓ Engine Speed – under / over
- ✓ Engine Oil Pressure – low
- ✓ Engine Temp – low / high
- ✓ Battery Voltage – low / high
- ✓ Weak Battery
- ✓ Fail to Start / Stop
- ✓ Charge Alternator Fail
- ✓ Over Current & Load (kW/kVAr)
- ✓ Unbalanced Load
- ✓ Independent Earth Fault
- ✓ Reverse Power
- ✓ Loss of Speed Signal

### Instruments

- ✓ Gen. Voltage (L-L/L-N)
- ✓ Gen. Frequency
- ✓ Engine speed
- ✓ Oil Pressure
- ✓ Water Temperature
- ✓ Battery Voltage
- ✓ Run Time
- ✓ Phase Sequence
- ✓ Power monitoring (kWh/kVAh/kVArh)
- ✓ Power (kWh/kVAh/kVArh)
- ✓ Power Factor
- ✓ Generator Current
- ✓ Generator Load (%)
- ✓ Earth Current



**Enclosure Features**

- ✓ Heavy Duty Steel / Aluminum Structure
- ✓ E-Stop on Enclosure
- ✓ Control Panel Eliminated from Engine Vibrations
- ✓ Standard Sound Attenuation Foam
- ✓ Plastic Covered Corrosion Resistant Locks & Hinges

**Enclosure Features**

- ✓ Internally Mounted Exhaust System with Rain Cap
- ✓ Coolant Fill Cap
- ✓ Removable Base Frame Lifting Hooks
- ✓ Oil & Coolant Drain Ports
- ✓ Easy Access for Maintenance

**Open Skid Gen-Set Dimensions**

Length	92 in
Width w/o lift hooks	43.3 in
Height	53.5 in
Dry Weight	2700 lb

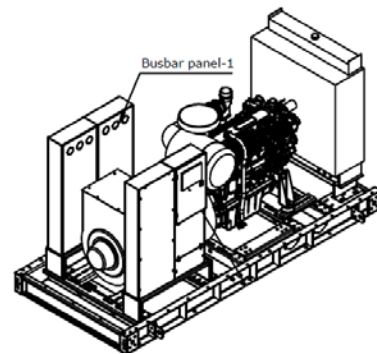

**Enclosed Gen-Set Dimensions – Level 1**

Length	116 in
Width w/o lift hooks	43.3 in
Height	66 in
Dry Weight	3900 lb
Sound Pressure @ 7 meters	76 dBA

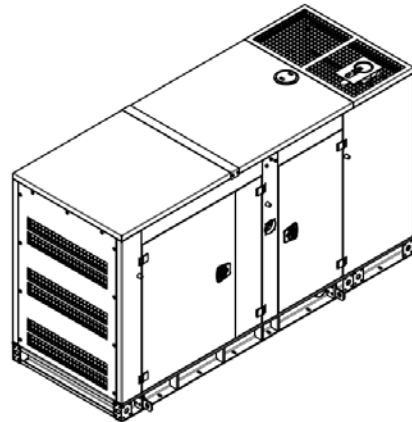

**Enclosed Gen-Set Dimensions – Level 2**

Length	116 in
Width w/o lift hooks	43.3 in
Height	82 in
Dry Weight	4200 lb
Sound Pressure @ 7 meters	72 dBA

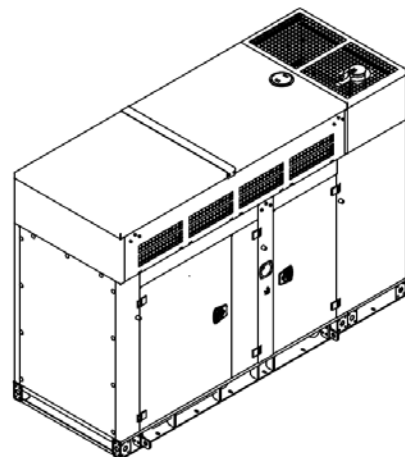

\*Manufacturer reserves the right to make changes in model, technical specifications, color, equipment and accessories without prior notice.

**Standard Features & Accessories**

- ✓ UL2200 Certification
- ✓ Heavy Duty Steel Base Frame
- ✓ PMG
- ✓ Engine Jacket Water Heater
- ✓ Battery and Battery Rack
- ✓ Battery Charger
- ✓ Anti Vibration Pads between Engine/Alternator & Base Frame
- ✓ Critical Grade Silencer Inside Enclosure
- ✓ Residential Grade Silencer Set for Open Skid Sets
- ✓ Exhaust outlet rain cap and radiator fill cap
- ✓ Sound Absorb Foam Material for Enclosure
- ✓ Emergency Stop Button
- ✓ Oil Drain Valve
- ✓ Coolant Drain Valve
- ✓ Jacket Water Heater Isolation Valves
- ✓ Flex Fuel Lines
- ✓ Secondary Lock-off Valve on Baseframe
- ✓ Engine Manifold Cover
- ✓ Turbocharger Cover
- ✓ Protection Covers for Rotating Parts
- ✓ Exhaust Insulation Cover
- ✓ Enclosure DC Light
- ✓ Operations Manual
- ✓ 24 Months / 2000 hours Limited Standby Warranty

**Optional Accessories**

- Main Line CB (3 / 4 Poles – 80% / 100% rated)
- Upsize Alternator
- Anti-condensation Heater
- Voltage Regulation  $\pm 0.5\%$  w/MX321 AVR
- Gas Regulator
- NG / LP Auto Changeover Control System
- Low Gas Pressure Alarm
- Low Coolant Level Alarm
- Oil Pan Heater
- Oil Temperature Display on Controller
- Manual Speed Adjust Rheostat
- Manual Voltage Adjust Rheostat
- Remote Annunciator Panel
- Remote Control & Monitoring Panel
- Advanced SMS Messaging
- Control Panel Heater
- Battery Disconnect Switch
- Battery Heater
- Battery Charger 10/20 Amp
- Shunt Trip / Aux Contacts
- Spring Anti-vibration Isolators
- Automatic Transfer Panel (ATS)
- 5 Years / 2000 hours Limited Comprehensive Warranty

**AKSA POWER GENERATION USA LLC**

371 Exchange Street, West Monroe,  
Louisiana, 71292

Tel: 318.855.8377 Fax: 318.855.8381

E-mail: sales@aksausa.com

AKSA Power Generation USA is a member of

**KAZANCI HOLDING****DISTRIBUTED BY:**