



AKSA Power Generation has been producing industrial generator sets with an innovative compact design and excellence in quality for over 30 years. AKSA has been providing reliable power through three main production plants and over 15 branch offices worldwide.

General Characteristics

Model Name	ANG100P
Engine Make	PSI
Engine Model	5.7LT-CAC
Alternator Make	Stamford
Alternator Model	UCI274C
Control Panel Make & Model	DSE 7320
Frequency & Speed	50Hz, 1500rpm
Enclosure Make & Model	AKSA AUL 41



Genset Rating @ 400/231v, 1500RPM, 0.8pf

Fuel Type	Stand-by Power	Stand-by Current	Prime Power	Prime Current
Natural Gas	100kVA / 80kW	144.3 A	NA	NA
LP Gas	90kVA / 72kW	129.9 A	NA	NA

Stand-by Power (Maximum): Power available at variable load in the event of main power network failure. No over load is permitted.
 Prime Power: Power available at variable load in lieu of a main power network. Overload of 10% is permitted for 1 hour in every 12 hours of operation.
 The above ratings represent the engine performance capabilities to conditions specified in accordance with ISO 8528/5 & ISO3046.
Derating may be required for conditions outside of the test conditions.

Codes & Standards

The Generator set is designed and manufactured in a facility certified to **ISO9001** standards.

The Generator set is designed and manufactured in a facility certified to **ISO14001:2015** standards.

AKSA Power Generation provides **single source responsibility** for the generator set & accessories.

The generator set, with its components, are **prototype tested** and **production tested**.

The generator set meets **NFPA70, 99, 110, 37** Level 1 when equipped with the necessary accessories and installed per NFPA standards.



*Manufacturer reserves the right to make changes in model, technical specifications, color, equipment and accessories without prior notice.



Engine Data

Manufacturer	PSI
Model	5.7LT CAC – GM V Type
Displacement & Cylinders	5.7L / 8 Cylinders
Engine Speed	1500rpm
Engine Standby Power (NG/LP)	100 kW / 92 kW
Engine Prime Power (NG/LP)	NA
Aspiration	Forced Induction
Compression Ratio	9.4 : 1
Bore / Stroke	101.6 mm / 88.4 mm
Governor	Electronic
RPM Range	1500 – 1800 rpm
Rotation Viewed from Flywheel	Counter Clockwise
Firing Order	1-8-4-3-6-5-7-2
Dry Weight (long block)	196 kg

Fuel System

Fuel Type	NG
Max EPR Rated Pressure	6.9 kPa
Recommended Max Running Pressure to EPR	2.7 kPa
Recommended Min Running Pressure to EPR	1.7 kPa
Min NG Supply Pipe Size	1-1/4" NPT
Min LPG Supply Pipe Size	3 / 4 "

Fuel Consumption @ Rated Power

NG	22.5 kg/hr
LP	NA

Electric System

Engine Cranking Motor	12V
Engine Battery Charge System	Negative Ground
Battery Qty, Rating, CCA	1 x 60Ah, 640CCA

Cooling System

Coolant Capacity –engine only	7.8 L
Heat Rejected to Cooling Water @ Rated Load	16.5 kcal/sec
Cranking Temperature	71 °C
Full Open Temperature	85 °C
Max Top Tank Temperature	NA

Exhaust System

Type	Air Cooled Manifold
Exhaust Pipe Size	4 inches
Max Allowable Back Pressure	10.2 kPa
Exhaust Volumetric Flow at Rated Power @ 1350 F	20.17 m ³ / min

Air Intake System

Max Intake Air Restriction – Clean Element	1.49 kPa
Max Intake Air Restriction – Dirty Element	3.24 kPa
Combustion Air Required	6.25 m ³ / min

Lubrication System

Oil Specification	SAE 5W-30 API
Max Allowable Oil Temperature	121 °C
Engine Oil Capacity	4.7 L



Alternator Data

Manufacturer	Stamford
Standards	BS EN 60034
Control System	Self Excited
A.V.R.	MX341
Voltage Regulation	± 1 %
Insulation System	Class H
Protection	IP23
Rated Power Factor	0.8
Stator Winding	Double Layer Concentric
Winding Pitch	Two Thirds
Winding Leads	12
Telephone Interference	THF < 2 %
Waveform Distortion	No Load < 1.5 %
Maximum Over speed	2250 rev/min

Controller Data

Manufacturer	DSE
Model	7320
Type	Auto Mains Failure Control

Controller Features & Benefits

- Microprocessor controlled
- License free PC Software
- IP65 rating offers increased resistance to water ingress
- Modules can be integrated to building management systems
- Real time clock provides accurate event log
- Four line back-lit LCD text display
- Five key menu navigation
- Front panel editing with PIN protection
- Support up to three remote display modules
- Configurable timers and alarms

Battery Charger & Electrical System Data

Manufacturer	Com-ap
Model	Inteli Charger
Input Voltage	100V ~ 277V AC
Output Voltage / Current	12V DC / 6A

- Multiple date and timer scheduler
- Integral PLC editor
- 'Protections disabled' feature
- kW & kVAr protection
- Reverse power (kW & kVAr) protection
- Power monitoring (kWh, kVAr, kVAh, kVArh)

Jacket Water Heater Data

Manufacturer	Hot-start
Model	TPS10GT10-000
Input Voltage	120V, 1ph
Power	1000W

- Load switching (load shedding and dummy load outputs)
- Unbalanced load protection
- Independent Earth Fault trip
- Fully configurable via DSE Configuration Suite PC Software
- SCADA monitoring via DSE Configuration Suite PC Software

*Manufacturer reserves the right to make changes in model, technical specifications, color, equipment and accessories without prior notice.



Enclosure Features

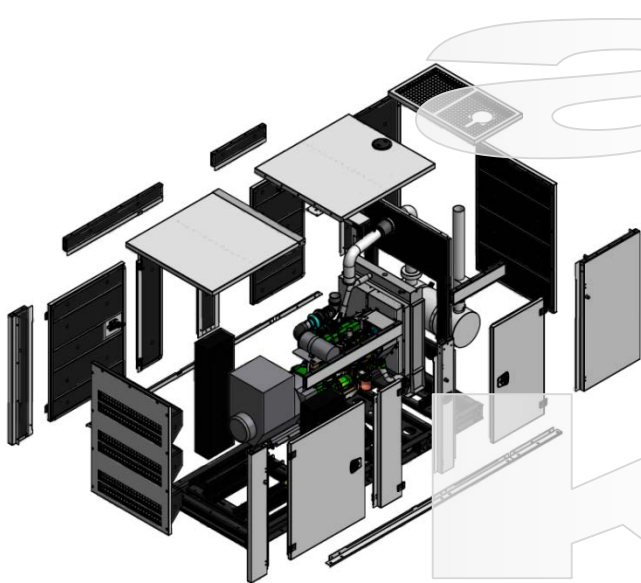

- ✓ Heavy Duty Steel Structure
- ✓ E-Stop on Enclosure
- ✓ Control Panel Eliminated from Engine Vibrations
- ✓ Breaker Panel Eliminated from Engine Vibrations
- ✓ Plastic Covered Corrosion Resistant Locks & Hinges
- ✓ Internally Mounted Exhaust System with Rain Cap
- ✓ Coolant Fill Cap
- ✓ Lifting Hooks on Base-frame
- ✓ Fuel Supply Connection Port on Base Frame
- ✓ Easy Access for Maintenance
- ✓ Sound Absorb High Density Foam

Open Skid Gen-Set Dimensions

Length	2340 mm
Width	1262 mm
Height	1360 mm
Dry Weight	960kg
Tank Capacity	NA

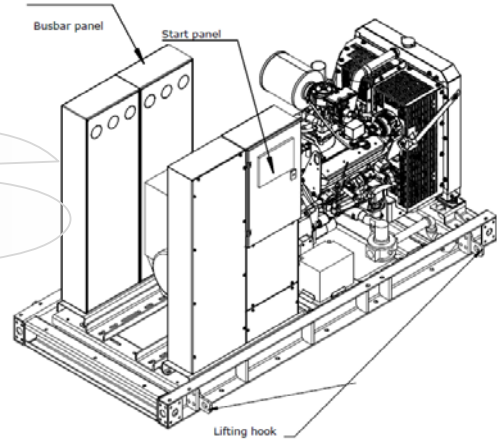

Enclosed Gen-Set Dimensions

Length	2950 mm
Width	1262 mm
Height	1682 mm
Dry Weight	1500kg
Tank Capacity	NA
Sound Pressure @ 7 meters	74 dBA

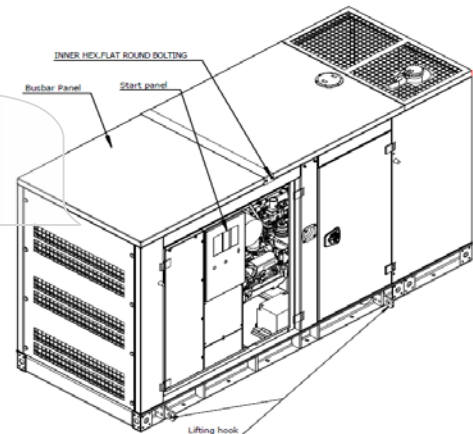

*Manufacturer reserves the right to make changes in model, technical specifications, color, equipment and accessories without prior notice.



Standard Features & Accessories

- ✓ Heavy Duty Steel Base Frame
- ✓ Engine Jacket Water Heater
- ✓ Battery and Battery Rack
- ✓ Battery Charger
- ✓ Battery Restraint
- ✓ Anti Vibration Pads between Engine/Alternator & Base Frame
- ✓ Residential Grade Silencer Inside Enclosure
- ✓ Industrial Grade Silencer Set for Open Skid Sets
- ✓ Sound Absorb Foam for Enclosure
- ✓ Air Inlet & Outlet Rodent Guards
- ✓ Oil Drain Valve
- ✓ Coolant Drain Valve
- ✓ Flex Fuel Lines
- ✓ Engine Manifold Cover
- ✓ Turbocharger Cover
- ✓ Protection Covers for Rotating Parts
- ✓ Exhaust Insulation Cover
- ✓ Low Fuel Supply Alarm
- ✓ Low Water Level Alarm
- ✓ Operations Manual
- ✓ 24 Months / 2000 hours Limited Standby Warranty

Optional Accessories

- Main Line CB (3 / 4 Poles)
- Voltage Regulation $\pm 0.5\%$ w/MX321 AVR
- Anti-condensation Heater
- Oil Temperature Display on Controller
- Manual Speed Adjust Rheostat
- Manual Voltage Adjust Rheostat
- Remote Annunciator Panel
- Remote Control & Monitoring Panel
- Advanced SMS Messaging
- Control Panel Heater
- Battery Disconnect Switch
- Battery Heater
- 10A Battery Charger
- Battery Charge Ammeter
- Oil Pan Heater
- LP Vaporizer for Liquid Fuel Supply Systems
- Dual Fuel Auto Changeover System
- Spring Isolators
- Synchronization System
- Automatic Transfer Panel (ATS) – Contactor Design
- Automatic Transfer Panel (ATS) – Changeover Design

*Manufacturer reserves the right to make changes in model, technical specifications, color, equipment and accessories without prior notice.

Aksa Power Generation USA
 371 Exchange Street, West Monroe, LA 71292
 T: + 1 318 8558377
 sales@aksausa.com

**Aksa Power Generation
 USA & LATAM**
 a member of



KAZANCI HOLDING

Aksa Power Generation LATAM
 12320 NW 116th Street, Miami, FL 33178
 T: + 1 786 4936857
 sales@aksausa.com